

new

Infrared measuring technology

Infra-red transmitter for measuring the surface temperature AMiR 7834 probe head for industrial application, with mA output (two-wire technology)

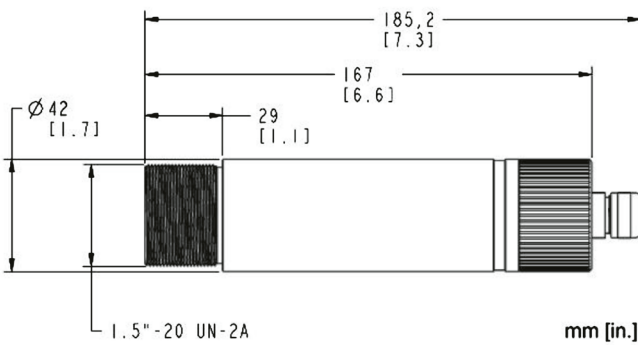

- Precise measurement of the surface temperature in industrial processes.
- **New:** sturdy stainless steel housing, protection class IP65.
- Broad temperature range from -40 to 2000 °C.
- Several spectral ranges for a variety of materials and use cases.
- Emissivity of the measuring surface can be manually adjusted on the probe head.
- Several optical resolutions and focal points.
- **New:** integrated laser (except 7834-10) for easy positioning of the probe head. Supply of the laser via the USB port.
- Analog output 4 to 20 mA in two-wire technology.
- **New:** USB port for configuring the analog output range, further probe head parameters and the signal processing (average value, maximum value, and minimum value).
- Easy installation. Extensive range of accessories, i.a. a high temperature protective housing.
- Connection cable for ALMEMO® data logger. Sensor power supply via the ALMEMO® device.

! On request:
Intrinsically safe probe heads approved for various purposes in areas with potentially explosive atmosphere (gas/dust).

Type	Measuring range	Spectral range	Optical resolution / focal point (refer to Measuring Field Diagrams)	Order no.
AMiR 7834-10x , without laser, with plastic lens, i.a. suitable for food etc.				
AMiR 7834-10SF0	-20 to 600 °C	8 to 14 µm	15:1 / 101.3 mm at 1520 mm	MR783410SF0
AMiR 7834-10CF0	-20 to 600 °C	8 to 14 µm	7:1 / 7.1 mm at 50 mm	MR783410CF0
AMiR 7834-11x/-12x with laser, for low temperature measurements, i.a. thick plastics, asphalt, carpets, coated papers, thermoforming etc.				
AMiR 7834-11SF0	-20 to 600 °C	8 to 14 µm	33:1 / 46.1 mm at 1520 mm	MR783411SF0
AMiR 7834-11CF1	-20 to 600 °C	8 to 14 µm	33:1 / 2.3 mm at 76 mm	MR783411CF1
AMiR 7834-11CF2	-20 to 600 °C	8 to 14 µm	33:1 / 6.1 mm at 200 mm	MR783411CF2
AMiR 7834-12SF0	-40 to 1000 °C	8 to 14 µm	50:1 / 30.4 mm at 1520 mm	MR783412SF0
AMiR 7834-12CF2	-40 to 1000 °C	8 to 14 µm	50:1 / 4 mm at 200 mm	MR783412CF2
AMiR 7834-21x with laser, for blast furnace lining, flame hardening, brazing etc.				
AMiR 7834-21SF0	200 to 1000 °C	3.9 µm	33:1 / 46.1 mm at 1520 mm	MR783421SF0
AMiR 7834-21CF1	200 to 1000 °C	3.9 µm	33:1 / 2.3 mm at 76 mm	MR783421CF1
AMiR 7834-21CF2	200 to 1000 °C	3.9 µm	33:1 / 6.1 mm at 200 mm	MR783421CF2
AMiR 7834-31x with laser, for surface temperatures of glass for bending, hardening, glowing, sealing etc.				
AMiR 7834-31SF0	250 to 2250 °C	5 µm	33:1 / 46.1 mm at 1520 mm	MR783431SF0
AMiR 7834-41x with laser, for foils PET, FEP, acryl, nylon, PU, PVC etc.				
AMiR 7834-41SF0	10 to 360 °C	7.9 µm	33:1 / 46.1 mm at 1520 mm	MR783441SF0
AMiR 7834-51x with laser, for ferrous metals / non-ferrous metals, induction heating, blast furnaces etc.				
AMiR 7834-51SF0	500 to 2000 °C	2.2 µm	60:1 / 25.3 mm at 1520 mm	MR783451SF0
AMiR 7834-51CF1	500 to 2000 °C	2.2 µm	60:1 / 1.3 mm at 76 mm	MR783451CF1
AMiR 7834-51CF2	500 to 2000 °C	2.2 µm	60:1 / 3.3 mm at 200 mm	MR783451CF2

DAkKS- oder Factory calibration KI9xxx temperature for sensor (see chapter Calibration certificates).
DAkKS calibration meets all the requirements regarding test resources laid down in DIN EN ISO/IEC 17025.

Infrared measuring technology

Technical data:

Accuracy:	$\pm 1\%$ of the measured value respectively ± 1.0 K for the measured temperature $> 0^\circ\text{C}$, (whichever value is higher). for measured temperature $< 0^\circ\text{C}$: $\pm(1.0 \text{ K} + 0.1 \times (0^\circ\text{C} - \text{measured temperature}))$. measured temperature in $^\circ\text{C}$
Reproducibility:	$\pm 0,3\%$ of measured value respectively ± 0.3 K (whichever value is higher).
Response time:	130 ms, for 7834-11 30ms, for 7834-31 60 ms
Nominal conditions:	$+23^\circ\text{C} \pm 5$ K, Emissivity factor 1.0 and calibration geometry
Emissivity:	0.10 to 1.00 manually adjustable on the probe head
Signal processing:	Averaging, maximum and minimum value retention, extended maximum and minimum value retention, compensation of background temperature
Power supply:	12 to 24 VDC
Analog output:	via terminals, 4 to 20 mA linear, two-wire technology, load < 500 Ohm. Analog output range can be configured via USB
ALMEMO® application:	To acquire and save measured values, we recommend our ALMEMO® 4390-2 panel meters. For further ALMEMO® devices, see chapter ALMEMO® Measuring Instruments
Alarm relay:	via terminals, load capacity 24 V 150 mA 1 limit value configurable via USB
Digital interface:	USB 2.0, micro B-plug (only for sensor set-up)
Laser:	for positioning of the probe head, power supply via USB.
Operating temperature:	without cooling: -20 to 85°C , with air-cooling: 10 to 120°C with water-cooling: 10 to 175°C with Thermo jacket protection housing and water cooling: 10 to 315°C
Air humidity:	10 to 95 % RH at 30°C , non-condensing during operation and storage.
Material:	stainless steel (housing)
Protection class:	IP 65 (IEC 60529)
Dimension:	without water cooling housing: Length 186 mm, \varnothing 42 mm
Weight:	without water cooling housing: 500 g

Accessories

Order no.

ALMEMO® connecting cable, directly mounted on the probe head, length 2 meters, with ALMEMO® connector, programmed for the probe head's temperature range, sensor supply via ALMEMO® device (use of the device mains unit is recommended)

ZA7838AK

For further accessories (protective window, cooling housing, thermo jacket etc.), see the following pages

Option

Order no.

Factory test certificate (only with delivery of new devices).

OR7834KZ1

Measuring Field Diagrams

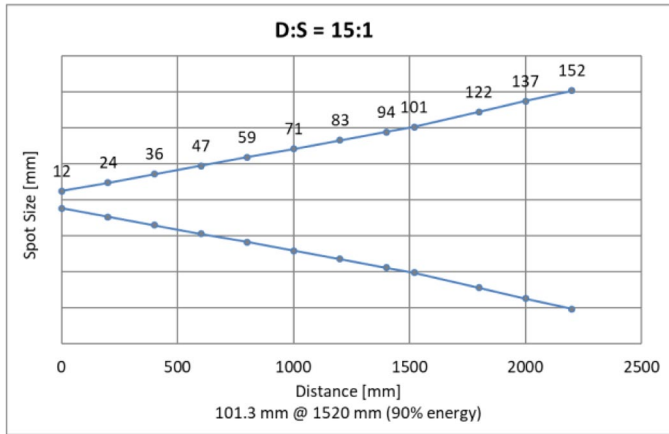

AMiR 7834-10SF0

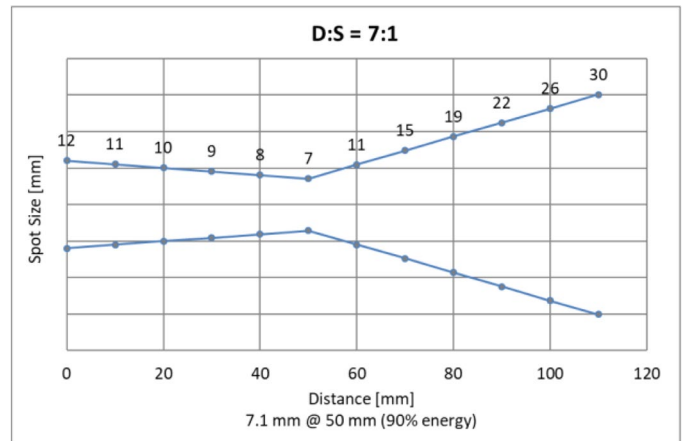

AMiR 7834-10CF0

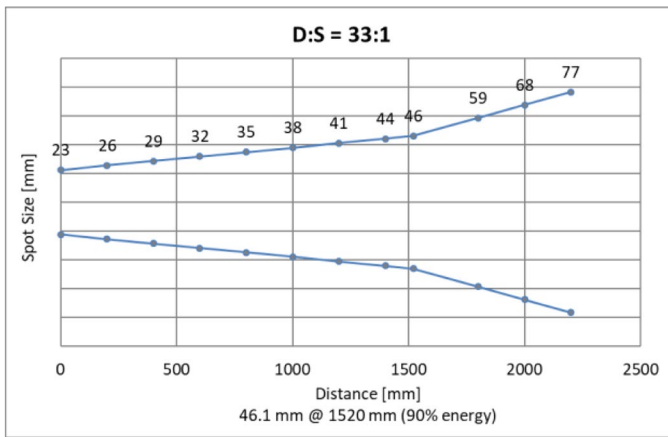

AMiR 7834-11SF0
AMiR 7834-21SF0
AMiR 7834-31SF0
AMiR 7834-41SF0

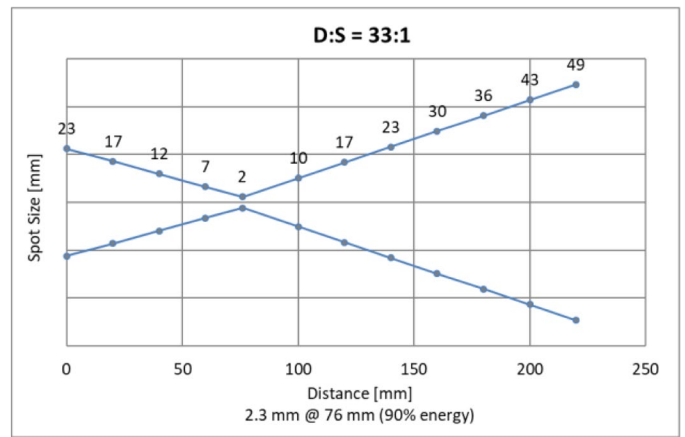

AMiR 7834-11CF1
AMiR 7834-21CF1

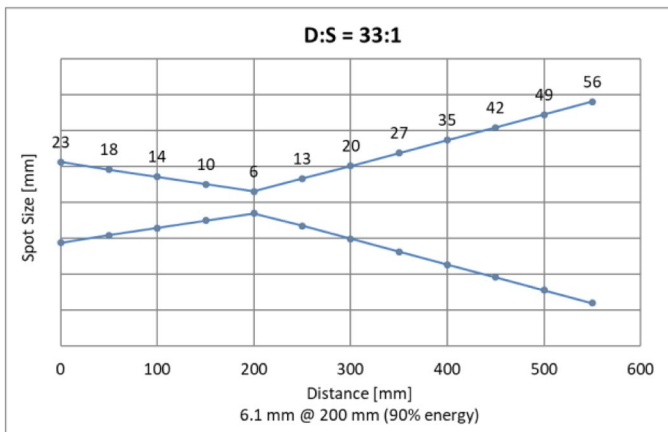

AMiR 7834-11CF2
AMiR 7834-21CF2

Infrared measuring technology

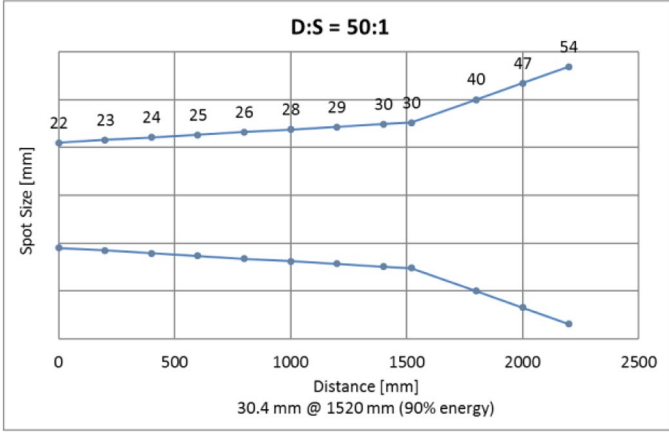

AMiR 7834-12SF0

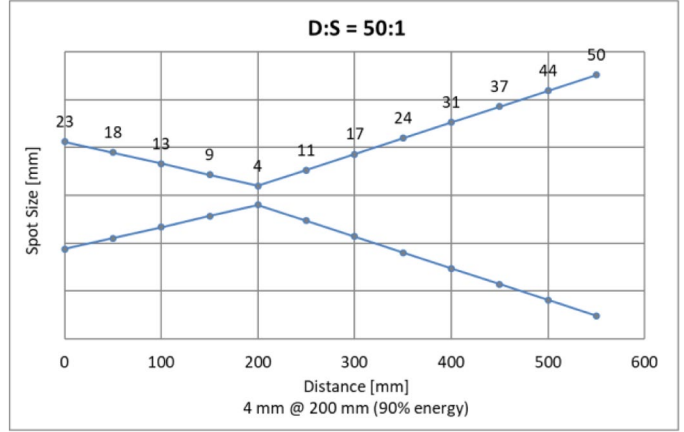

AMiR 7834-12CF2

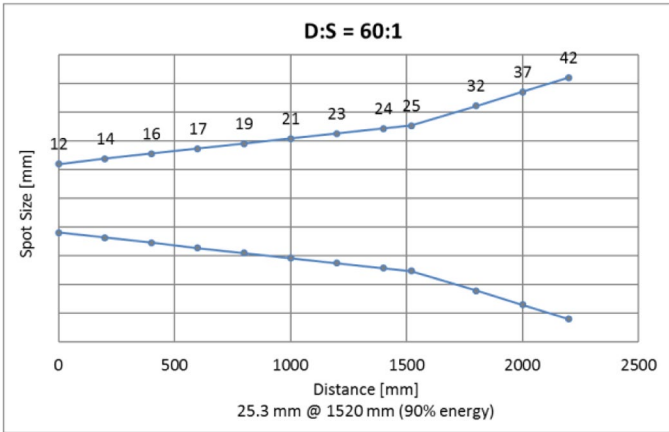

AMiR 7834-51SF0

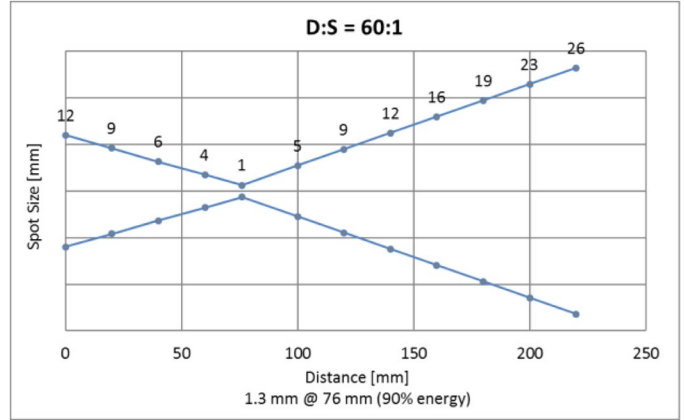

AMiR 7834-51CF1

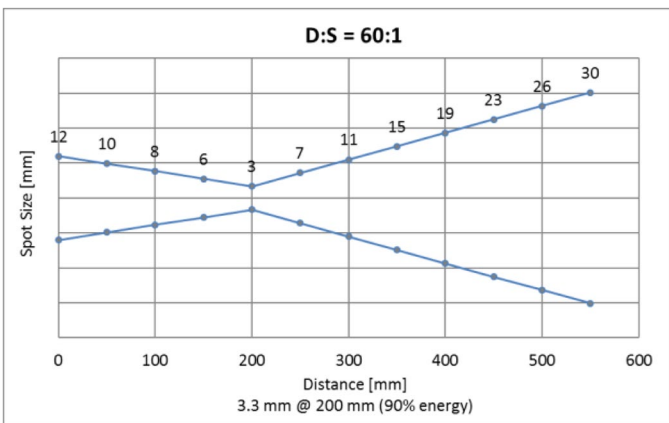

AMiR 7834-51CF2

Accessories for the probe heads AMiR 7834 without the use of the thermo jacket protection housing

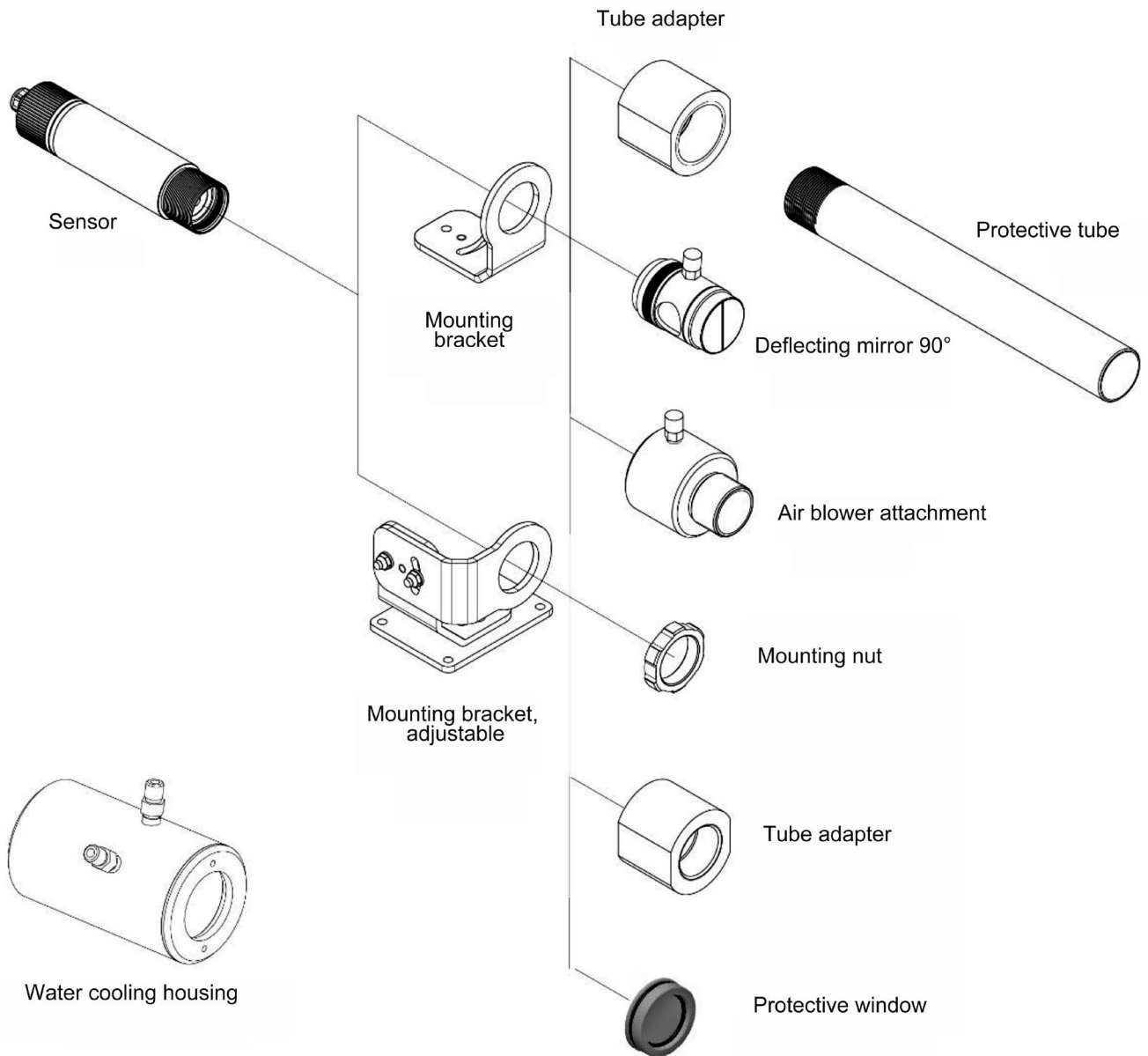

Accessories

Protective window attached for probe head MR 7834-10x, material: plastic foil
 Protective window attached for probe head MR 7834-11x/-12x, material: zinc sulfide
 Protective window attached for probe head MR 7834-21x, material: sapphire
 Protective window attached for probe head MR 7834-31x/-41x, material: calcium fluoride
 Protective window attached for probe head MR 7834-51x, material: glass
 Water cooling housing including air blower attachment
 Air blower attachment
 Deflecting mirror 90°
 Mounting bracket, adjustable
 Mounting bracket, rigid (spare)
 Securing nut (spare)
 Tube adapter for protective tubes
 Stainless steel protective tube, 30 cm
 Ceramic protective tube, 30 cm

Order no.

ZR7834SFLTPF
 ZR7834SFLT
 ZR7834SFMT
 ZR7834SFG5P7
 ZR7834SFHT
 ZR7834KL
 ZR7834LB
 ZR7834US
 ZR7834JH
 ZR7834H
 ZR7834BM
 ZR7834RA
 ZR7834RE
 ZR7834RK

Infrared measuring technology

Accessories for the probe heads AMiR 7834 using the thermo jacket protection housing

10/2021 • We reserve the right to make technical changes.

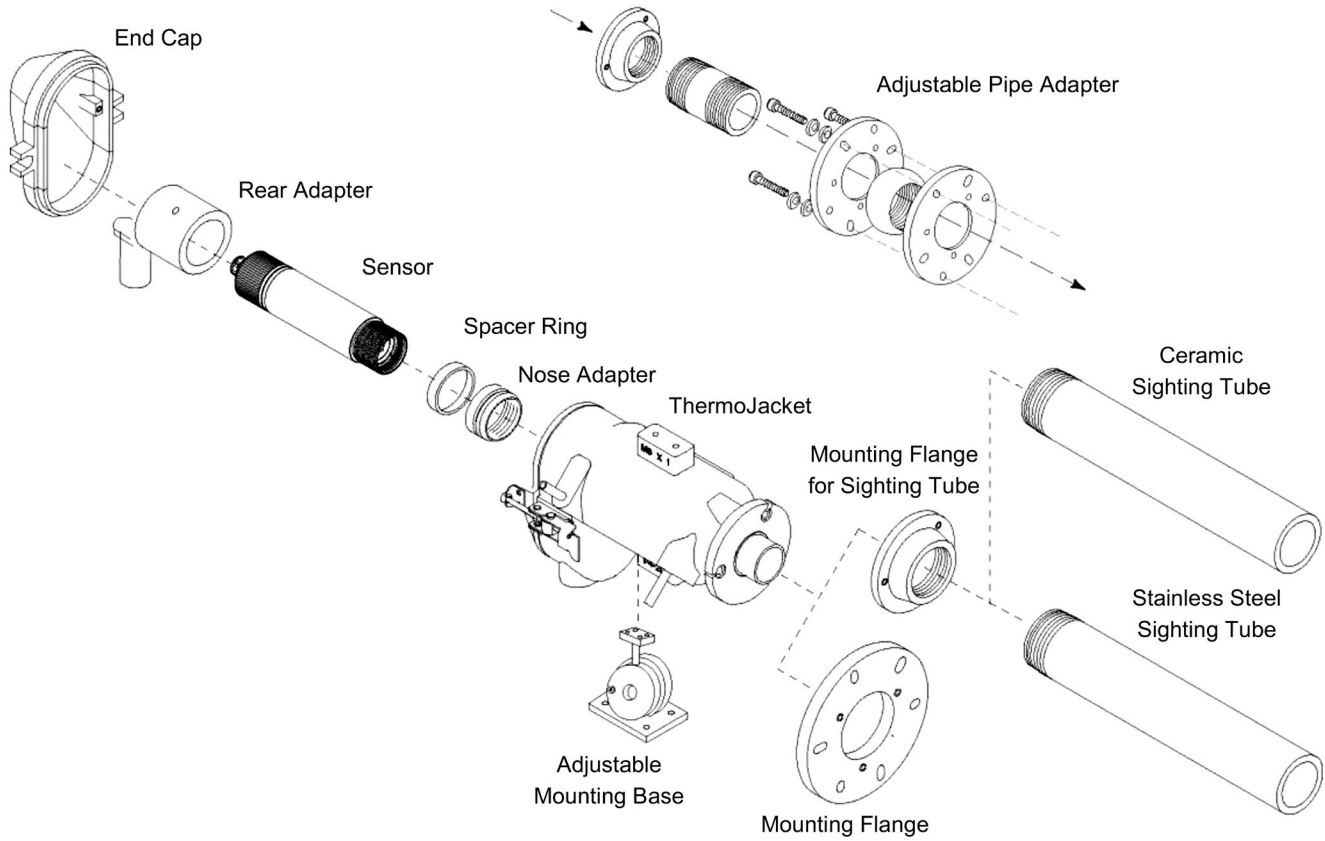

Accessories

Order no.

Thermo jacket protection housing	ZR7834SH
Mounting flange for thermo jacket	ZR7834TJMF
Adjustable mounting flange for thermo jacket	ZR7834TJMB
Adjustable tube adapter for thermo jacket	ZR7834JR
Mounting flange for protective tubes for thermo jacket	ZR7834TJFR
Stainless steel protective tube, 30 cm	ZR7834RE
Ceramic protective tube, 30 cm	ZR7834RK